



**MEGA**  
ELECTRONICS INC.

**Powercords  
and Related  
Components**

Quality service and quality products. Produced in ISO9000 facilities, our UL listed and internationally approved powercords and related components all conform to the highest standards.

Upon your next requirement, please keep MEGA in mind.

**MEGA Electronics Inc.**  
4B Jules Lane  
New Brunswick, New Jersey, 08901  
tel. 732.249.2656 fax. 732.249.7442  
[www.megaelectronics.com](http://www.megaelectronics.com)  
[sales@megaelectronics.com](mailto:sales@megaelectronics.com)

**MEGA Electronics, Inc.**  
**4-B Jules Lane**  
**New Brunswick, NJ**  
**08901**

**Tel. (732) 249-2656**  
**Fax. (732) 249-7442**

[www.megaelectronics.com](http://www.megaelectronics.com)

**MEGA**  
ELECTRONICS INC.

Powering Your Products

# Power Cord Guide to Global Standards

---

Please find following a guide to specifying the correct power cord to be used with your power supply to meet domestic and international standards.



# Power Cord Products

The Company headquarters and engineering support are located in New Jersey. ISO 9001 certified production facilities in the Philippines and Huizhou, Guangdong China are vertically integrated. Cord set production begins with the drawing of 8mm copper rods down to sizes as small as 0.05mm and includes all aspects of production from extrusion to molding of couplers all in house.

The combination of vertical integration and the UL listing for cord sets and wire harnesses in New Jersey combine to allow MEGA to provide you with the fastest possible service at the most reasonable prices.

# Guide to specifying cord sets and power cords

---

- What plug is required?
  - How many amps and volts? (i.e. 10A/125V, 10A/250V, etc.)
  - How many conductors? (Most common 2 or 3)
- What cordage is required?
  - What size, temperature rating, color, conductor colors?
- Is a connector required?
  - If yes, which type? (i.e. C7, C13, C19)
  - If no, what end preparations are required:  
ROJ(Remove outer jacket) + Strip (conductors), tinning, terminals?
- What length is required?
- Optional extras: special packaging, bagging, blister pack, labeling, etc.

Note: The completed cord set will be rated only as high as the lowest rated components

# North American NEMA Standards

---



## N1/15P Rated 15A/125V

- Available polarized (Wide blade) or non-polarized
- For use with all two-conductor cordages



## N5/15P Rated 15A/125V

- For use with all three-conductor cordages
- Also available with cord grip



## N6/15P Rated 15A/250V

- For use with all three-conductor cordages
- Horizontal pins

See catalog page 4-14

# North American NEMA Standards

---



- N5/20P Rated 20A/125V
  - For use with all three-conductor cordages



- N6/20P Rated 20A/250V
  - For use with all three-conductor cordages



- N6/30P Rated 30A/250V
  - The plug designations and ratings continue to increase. To view additional NEMA straight blade plugs.

See page 14 in catalog



# Hospital Grade NEMA Plugs

A special use section of cord sets had been created for use on medical and dental equipment as defined by UL 544, which has since been replaced by UL60601. The purpose of this regulation is to provide a "safer" environment for patients coming into contact with medical equipment. This is achieved through the following requirements:

- **Solid plug pins to lower the risk of bending**
- **Larger bodies lower the risk of wire to outer contour shock**
- **Plug surface skin testing**



- In addition to the above, hospital grade cord sets are required to meet the standard testing requirements under UL and CSA(cUL) per UL 817. Once approved, the plugs will be stamped with the "Green Dot" on the plug face.

- As added safety precautions MEGA solders the conductors to the plug pins and adds a hog ring to the cable prior to over molding the plug, further increasing cable retention force.

- Tooling is in place for the hospital grade plugs in the below configurations:

NEMA 5/15(15A/125V) NEMA 6/15(15A/250V)

NEMA 5/20(20A/125V) NEMA 6/20(20A/250V)



See catalog pages 10-11

# Molded Twist Lock Cord sets

---

The use of twist locks is becoming increasingly more common when the flow of continuous power is critical. The use of the twist lock ensures that once the plug has been inserted and turned (“locked”), the plug cannot be removed by tripping over a wire or by similar accidents. The twist lock mirrors the nomenclature of the NEMA standards in regards to amperage and voltage rating, but differ significantly in plug shape and configuration.



See catalog page 9



# Additional NEMA Angle Plugs

---



Plugs are available with various cordage types and gauges. Ratings shown in catalog are the highest allowable by appropriate standards. Ratings will vary with cordage gauges.

See catalog pages 12-13



# NEMA 5/15P with Circuit Breaker

---



The circuit breaker is UL recognized to 15A/125VAC-60Hz and has a push to reset function. UL listed for use with 12 - 16AWG SJT, SJTO, and SJTOW cable, it is suitable for indoor and outdoor applications. For use in hard wire power cord, detachable cord set or extension cord applications.

See catalog page 13

# Dryer and Range Cords

---



NEMA 10/30P (Dryer type)

30A 125A/250V

SRDT 10/4C

NEMA 10/50P

50A 125V/250V

SRDT 10/3C, 8/3C, 6/3C

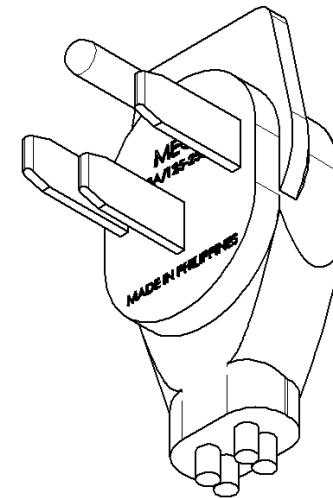

Custom Tooled  
N14/50P flat face

See catalog page 14

# Branched Power cords

---



Branches allow multiple devices to be run from a single power source. Branches can be used with a variety of plugs and cables. MEGA currently offers two and three way branches.

See catalog page 15

# Fully Molded Strain Reliefs

Fully molded threaded strain reliefs are available from our stock tooling or custom made.

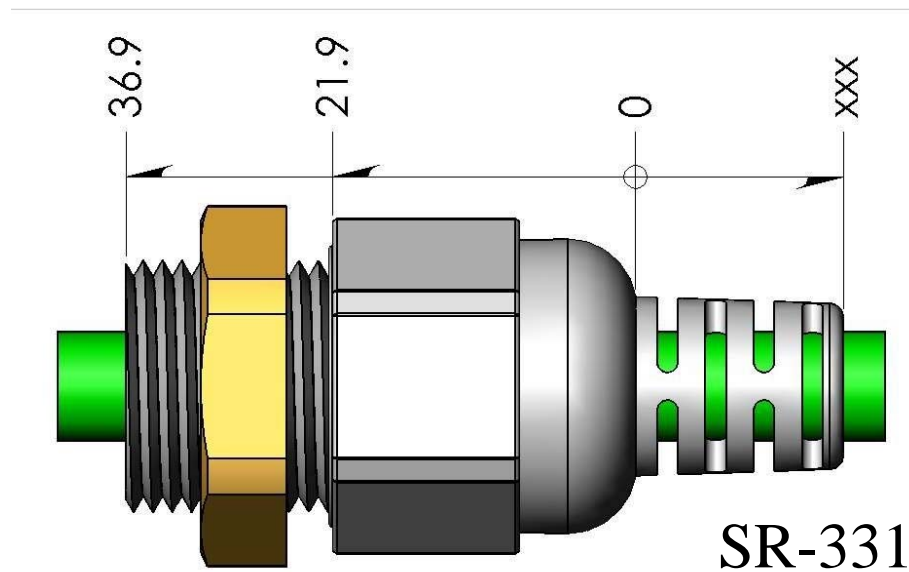

See catalog page 15



# International Three Conductor Plug Standards

---

<b>Country</b>	<b>Maximum AMP/V</b>	<b>Standard</b>
Continental Europe	16/250	CEE(7)VII
United Kingdom	13/250	BS 1363
(Singapore/Saudi Arabia/Gulf States)		(PSB/SASO2203/G Mark)
Italy	16/250	CEI 23-50(10A)/CEI 23-16(16A)
Switzerland	10/250	SEV 1011(Type 12)
Denmark	10/250	DS/IEC 60884-1 (Sheet DK2-1A)
Australia/New Zealand	15/250	AS/NZS 3112
Argentina	20/250	IRAM 2073
China	15/250	GB 2099.1-1996
Brazil	20/250	NBR14136
South Africa	16/250	SANS164-1 (Based on BS546)
India	16/250	IS 1293
Israel	16/250	S1 32/1971
Japan	15/125	JIS 8303
South Korea	16/250	K60884-1 & KSC8305
Taiwan	10/250	CNS10917
Thailand	16/250	TIS 166-2549

# Continental Europe

## Type: CEE 7 (VII) “Schuko”

The plug has two round pin contacts and two grounding clips on the sides of the plug body, allowing the plug to be inserted in sockets without regard to polarization. Only in France and Belgium is this plug polarized because of the permanently mounted pin in the socket which mates with the hole in the plug face. A very similar plug is used in South Korea. This plug will cover 75% of the European market.



Also available  
right angled

This plug will be used everywhere  
except the UK, Switzerland, Italy  
and Denmark

See catalog page 19

# Eurocord



For low amperage (2.5A250V)  
ungrounded applications the  
Eurocord (EN50075) can be used  
throughout Europe, except in the UK  
and Switzerland

See catalog page 19



# BS 1363 United Kingdom

As with most things, the Brits do things completely different than the rest of Europe with regard to their plug configuration. The plugs must have an internal fuse. 3AMP, 5AMP, 10AMP, or 13AMP fuses. The most commonly used fuse is the 13 Amp.



British plugs must be approved by ASTA or BSI for the UK, by PSB in Singapore, and Saudi Arabia has implemented a Product Conformity Program requiring a Certificate of Conformity also referred to as a SASO CoC to be cleared through Customs. The G-Mark for Low-Voltage Electrical products is regulated by the Gulf Technical Regulation for Low-Voltage Electrical Equipment and Appliances (BD-142004-01) and is required for products shipped to the UAE, Baharain, Qatar, Kuwait, and Oman. Saudi Arabia will accept the G Mark as well.

See catalog page 16

# Italian/Swiss/Danish

---



- Italian to 10A/250V  
Alternate plug to 16A/250V



- Swiss to 10A/250V

In 2013 it became mandatory for the Swiss plug to have insulated pins. A plug with square pins is approved to 16A.



- Danish to 13A/250V

Denmark has approved the Schuko plug, but this is infrequently used as it is ungrounded in Danish outlets. There is a separate plug standards for both data com and medical applications.

See catalog page 20-21

# Australia/New Zealand



The Australian plug can be approved by one of five state agencies. The standard plug is 10A/250V rated, but 15A and 20A models are available. Australian standard AS/NZS 3112 has been updated and as of April 3, 2005 requires the use of insulated line and neutral pins.

For hospital applications, a clear plug is recommended, but not required.

See catalog page 22

# Argentina

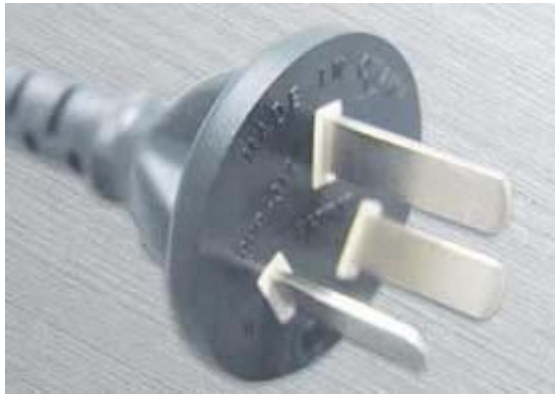

- The Argentine plug mirrors the Australian, except for three major differences: the plug pins are 1 mm longer, no safety contacts are required and the pin polarity is reversed. The IRAM approval is required.

See catalog page 24

# China

---



The 10A Chinese plug also mirrors the Australian, except that the contact pins are 1 mm longer and they are required to have the CCC approval.

In addition there is 16A, 250V plug under the standard GB 2099.1-2008, GB 1002-2008

China has implemented the Regulation for Pollution Control of Electronics Products (WEEE) to mirror the European RoHS



See catalog page 25

# Brazil



As of January 1, 2010 Brazil requires the use of the new plugs under standard NBR14136. The new plug is very similar to the Swiss standard.

There are now two conductor and three conductor standards in place



See catalog page 22

# South Africa/India-Israel

---



- South Africa use the old British style defined in BS546. For S. Africa the SABS approval to SANS 164-1 is required.
- India plug is per IS1293. BIS approval is now required on the power cord and the internal color code is now Black, Red, Green/Yellow, making it impossible to have one cord approved for both India and S. Africa.



- Israel's plug is defined in SI-32 and can be used in applications up to 16A/250V. The Europlug is used for 2 conductor applications

See catalog page 23

# Japan



The Japanese plug and the EN60320 C13 connector are specified in JIS 8303. Cord sets exported to Japan require the PSE approval and CTI. The plug configurations for Japan mirror the NEMA standards used in North America, with one major exception. Japanese mains occasionally do not provide for grounding and a molded two-prong plug with a grounding fork can be used to ground the cord set to the wall socket.

Use of medical grade plugs can be required by some hospitals in Japan, but this is a very infrequent request.

See catalog page 24



# Japan

## Comparative Tracking Index

The Comparative Tracking Index or CTI is used to measure the electrical breakdown (tracking) properties of an insulating material. To measure the tracking, 50 drops of 0.1% ammonium chloride solution are dropped on the material, and the voltage measured for a 3 mm thickness is considered representative of the material performance. Also, the term PTI (Proof Tracking Index) is used: it means voltage at which during testing on five samples the samples pass the test with no failures.

Tracking is an electrical breakdown on the surface of an insulating material. A large voltage difference gradually creates a conductive leakage path across the surface of the material by forming a carbonized track that could ultimately cause risk of fire.

PTI requirement on plugs surface has been introduced by Japan as a mandatory requirement approximately one year ago, you can see in attachment the PSE requirement.

All Japan plugs supplied by MEGA Electronics Inc are in conformity with the PTI requirement as they have been made with particular plastic materials and design specifications to assure that this test is passed.

# South Korea



The South Korean plug standard mirrors the Continental European plug, except that it required the KC approval mark (shown below). The cable type has been revised from the Japanese standard of the past to the European cable nomenclature.

As of 2012 the old KETI mark has been replaced by the KC (Korean Certification) mark. KETI approval documentation allows a manufacturer to apply the KC mark.



See catalog page 25

# Taiwan

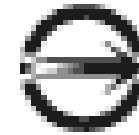

All powercord products to be used within Taiwan are required to have the new BSMI certification and mark. The BSMI mark (see above) is issued by the Bureau of Standards, Metrology and Inspection of the Ministry of Economic Affairs in Taiwan.

The plug mirrors the NEMA standards of North America, but the cabling is based on the Japanese system, the most common type being VCTF3x1.25mm.

See catalog page 25

# Thailand



Thailand has set a new standard TIS 166-2549. Within the standard are 2 and 3 conductor pin configurations, both having semi insulated pins.

Both plugs will be used in conjunction with European cable.



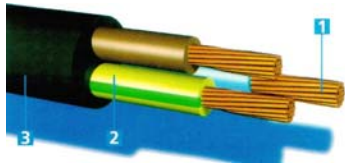

# Cordage Types

---

There are now five major types of cable possible:

UL/CSA (North America)

Harmonized (Europe)

Australian (Australia/New Zealand)

Japanese (Japan)

Chinese (China)

It is not permissible to ship products with cordage not approved for the country of destination, i.e. products cannot be shipped to Europe with UL/CSA cordage. The exception is that the Australian standard mirrors the European standard with minor differences and it is possible to make a cable that is approved by both jurisdictions.

# UL/CSA Cordage

UL listed cable is measured in the American Wire Gauge (AWG) system. The smaller the AWG the larger the size and rating. When used in conjunction with plugs or connectors the cable ratings are:

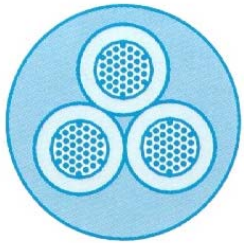

18AWG = 10Amps 12AWG = 20Amps

16AWG = 13Amps 10AWG = 30Amps

14AWG = 15Amps 8AWG = 50Amps

Internal color codes can be:

Black, white, green (or green/yellow)

or

Blue, brown, green/yellow

See catalog page 46-47

# Common Flexible UL/CSA Cords

TYPE	SHAPE	GAUGE	NO OF COND.	CONDUCTOR INSULATION	JACEKT MATERIAL	VOLT	REMARKS
SPT-1	Parallel	18	2	PVC	-	300	Light Duty, Lamps
SPT-2	Parallel	16-18	2-3	PVC	-	300	Light Duty, Lamps
SPT-3	Parallel	12-18	2-3	PVC	-	300	Refrigerators, Air Conditioners, Extension cords
SVT	Round	18	2-3	PVC	PVC	300	Vacuum Cleaners
SJ	Round	12-18	2-4	Rubber	Rubber	300	Small Appliances, Hand Tools
SJO	Round	12-18	2-4	Rubber	Neoprene	300	Oil Resistant Jacket, Small Appliances, Hand Tools
SJT	Round	12-18	2-4	PVC	PVC	300	Small Appliances, Hand Tools
SJTO	Round	12-18	2-4	PVC	PVC	300	Oil Resistant Jacket, Small Appliances, Hand Tools
SJTW	Round	12-18	2-4	PVC	PVC	300	Outdoor Use, Garden Tools
S	Round	12-18	2-4	Rubber	Rubber	600	Heavy (Hard) Duty Service
SO	Round	12-18	2-4	Rubber	Neoprene	600	Oil Resistant Jacket, Heavy (Hard) Duty Service
ST	Round	12-18	2-4	PVC	PVC	600	Heavy (Hard) Duty Service
STO	Round	12-18	2-4	PVC	PVC	600	Oil Resistant Jacket, Heavy (Hard) Duty Service
STW	Round	12-18	2-4	PVC	PVC	600	Outdoor Use, Garden Tools
HPN	Round	12-18	2-3	Neoprene	-	300	Heater Cord, Toasters, Heaters
HSJ	Round	12-18	2-4	Rubber	Rubber	300	Heater Cord, Oil Resistant Jackets

MEGA is now producing EV cables for electric vehicle charging

[www.megaelectronics.com](http://www.megaelectronics.com)



Powering Your Products

# European Cordage

European cables are measured in square millimeters.  
The larger the number the larger the cable and rating.

H 05 V V F 3 G 1.0mm

H = Harmonized (Does not signify <HAR>)

05 = 300/500V rating : 07 = 500V/700V rating

V = PVC : R = Rubber : N = Neoprene (Outer jacket/Conductor Jacket)

F = Fine Stranded

3 = The number of conductors

G = Grounded (For two conductor applications the G is absent)

See catalog page 48-49

The above is the most common power cord cable example  
MEGA stocks a variety of PVC and rubber European cables.



# European Cordage Sizes

When used in conjunction with plugs or connectors the cable ratings are:

0.75mm = 6Amps	2.5mm = 25Amps
1.0mm = 10Amps	4.0mm = 32Amps
1.5mm = 16Amps	6.0mm = 44Amps

Internal color codes must be blue, brown, green/yellow



MEGA can supply cable cut  
and terminated or in bulk

# Australian Cordage

---

Australian cable is very similar to the European cable, it is measured in cross sectional sizes, but Australia has a more stringent flammability rating. It is possible for European cable to also be approved by one of the state agencies in Australia as long as it meets the standards.

Approved cable will have a file number on the cable jacket.

# Japanese Cordage

---

Unlike the Japanese plug, which mirrors the NEMA styles, the cordage used in Japan is a completely different system. Not only is the approval different, but the cordage is measured in cross sectional sizes like the European system. But the similarity to the European cordage ends there, as the sizes and amperage ratings do not correspond.



# Japanese Cordage vs. UL/CSA

Japanese

UL/CSA

VFF

SPT-2

VCTF

SJT

HVCTF

SJT (Rated 75°C)

PNCTF

SJO

## Sizes and Ratings of Japanese Cordage

Cross Sectional Size

AMP Rating

0.75mm

7 AMPS

1.25mm

12 AMPS

2.00mm

15 AMPS

# Chinese

China has developed their own cable nomenclature, but the cable is measured in cross section sizes similar to European cable. All approved Chinese cable is required to be approved with the CCC (Chinese Compulsory Certification) marking. Below is a cross from CCC standards to European.

## IEC TO CCC AND CENELEC CONVERSION TABLE

IEC	CCC	CENELEC
227 IEC 52	RVV 300/300	H03VV-F 300/300
227 IEC 52 flat	RVVB 300/300	H03VVH2-F 300/300
227 IEC 53	RVV 300/500	H05VV-F 300/500
227 IEC 53 flat	RVVB 300/500	H05VVH2-F 300/500
245 IEC 51	RX 300/300	H03RT-H 300/300
245 IEC 53	YZ 300/500	H05RR-F 300/500
245 IEC 57	YZW 300/500	H05RN-F 300/500
245 IEC 66	YCW 450/750	H07RN-F 450/750

# COIL CORDS

Cords for the US Market are made from a PVC/TPE blend and are made to the BQF standard for Europe.



To learn about the coiling process click on the photo to link to the MEGA website

[www.megaelectronics.com](http://www.megaelectronics.com)



Powering Your Products

# EN60320 Molded Connectors

European / UL ratings

C7

2.5A/250V

10A/125V



C5

2.5A/250V

10A/125V



C17

10A/250V

15A/250V



C13

10A/250V

15A/250V



C15

10A/250V

15A/250V



C19

16A/250V

20A/250V



120C max.



See catalog page 18

# EN60320 Locking Connectors



Use locking outlets to create a completely secure connection.

**Suitable for use with  
'ANY STANDARD'  
C14 or C20 inlet**

- **Protects appliances that are vulnerable to vibration**
- **Connector cannot be accidentally pulled or vibrated out of the inlet**



# Universal Approved Jumper Cords

---

Jumper cords allow the transfer of power from one device to a second. Considered wiring harnesses, a single jumper cord can carry both the North American and European approvals making it universally approved.

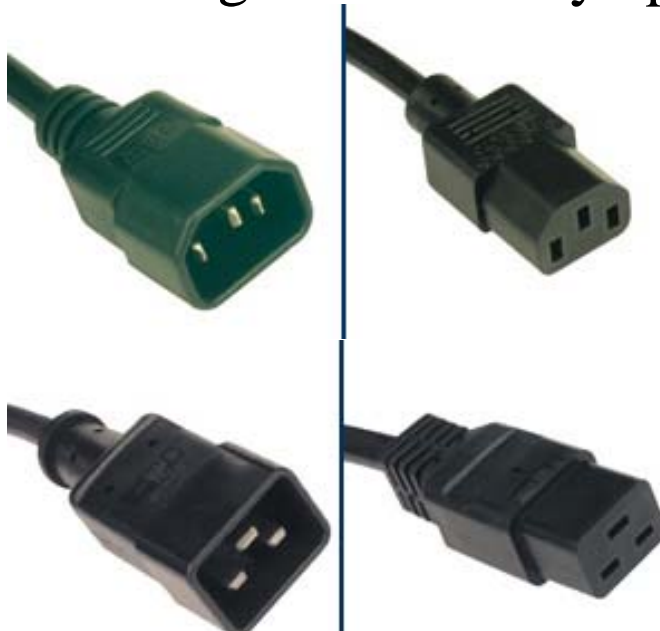

C14/C13

Rated:

15A(UL)10A(Europe)/250V

See catalog page 17

C20/C19

Rated:

20A(UL)16A(Europe)/250V

# Additional Products



## Power Supplies & Cords

- Wall Adapters with Interchangeable Plug Option
- Desk Top to 200W
- Open Frame with PFC
- DIN Rails to 960W
- LED Drivers
- Medical Approvals

**MEGA Electronics Inc.**  
4B Jules Lane  
New Brunswick, NJ 08901  
tel 732.249.2656 fax 732.249.7442  
[www.megaelectronics.com](http://www.megaelectronics.com)  
sales@megaelectronics.com



## DC/DC-AC/DC Converters

- Rated up to 150 Watts
- UL, cUL Recognized, CE Approved
- Isolations to 6kV for Medical Applications
- ROHS Compliant
- Short Lead Times
- High MTBF Rates
- Continuous Short Circuit Protected
- Website with Product Locator

**MEGA Electronics Inc.**  
4B Jules Lane  
New Brunswick, NJ 08901  
tel 732.249.2656 fax 732.249.7442  
[www.megaelectronics.com](http://www.megaelectronics.com)  
sales@megaelectronics.com

[www.megaelectronics.com](http://www.megaelectronics.com)

**MEGA**  
ELECTRONICS INC.

Powering Your Products